

Lecture 3: Visual Area V1

A.L. Yuille (UCLA)

Retina to LGN to the Visual Cortex

- Slide from Zhaoping Li

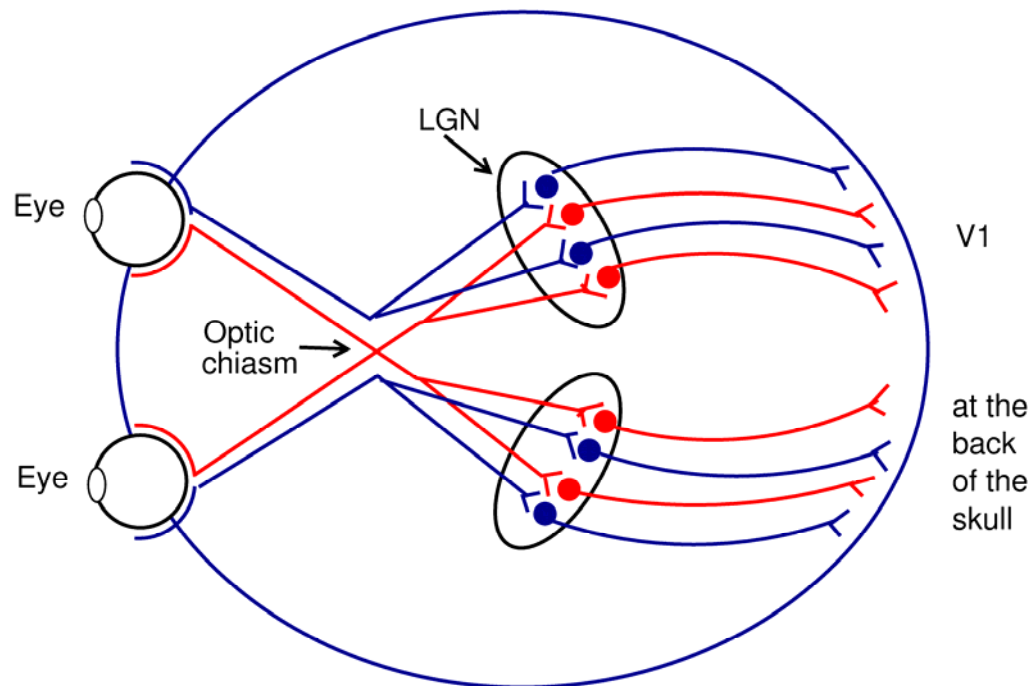

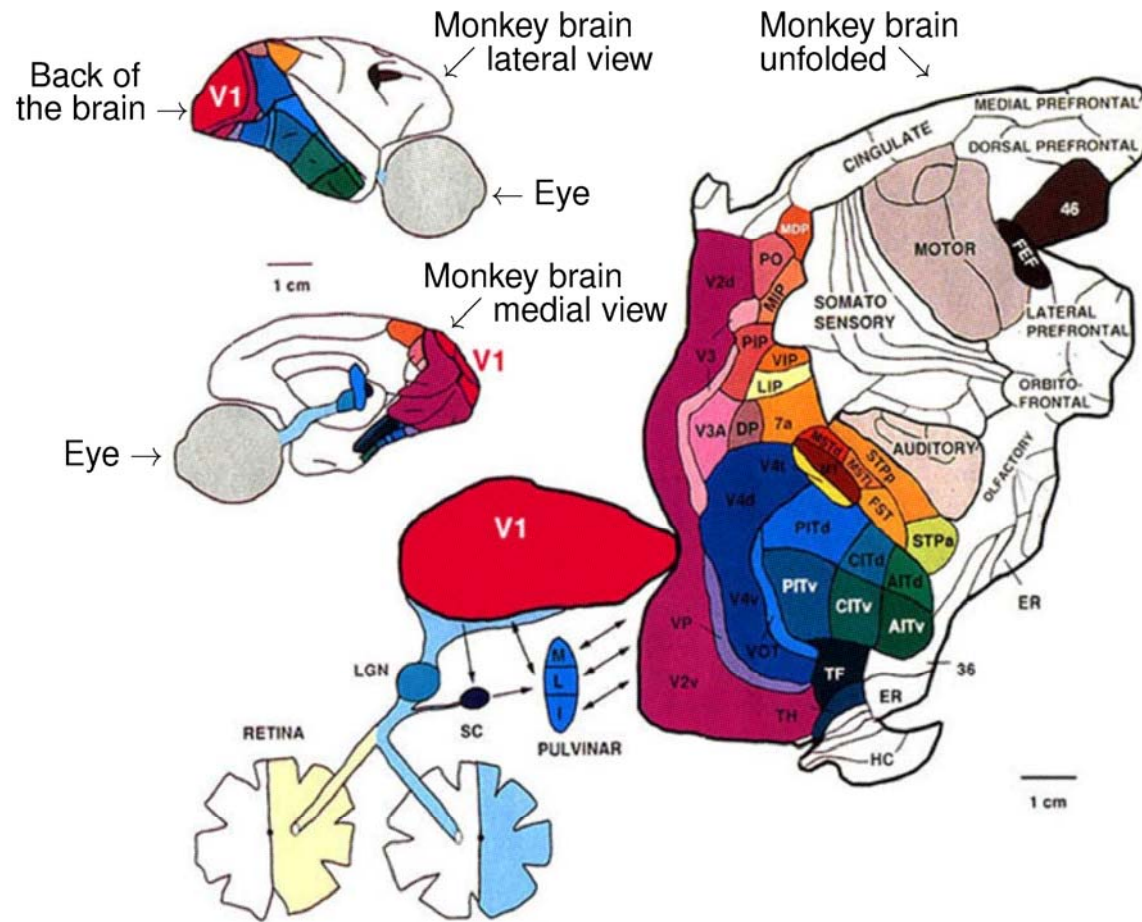

Figure from "Understanding Vision: theory, models, and data", by Li Zhaoping, Oxford University Press, 2014

Cortical Visual Areas and the relationships between them

The visual cortex can be decomposed into a number of visual areas based on anatomical and electrophysiological measurements [166]. The visual areas V1, V2, V4, Medial Temporal (MT), Medial Superior Temporal MST, and the Inferior Temporal Cortex (IT) are illustrated in figure (11). It is common to concentrate on two *hierarchical streams*:

(I) The *ventral stream* which consists of V1, V2, V4, (the functional organization of V3 has been under some debate) and then the infero-temporal (IT) areas of extrastriate cortex. This pathway is believed to perform object detection and scene understanding. The “what” pathway.

(I) The *dorsal stream* goes from V1, MT to the parietal cortex. It is believed that this is used for analysis of the movements and positions of objects as they relate to navigation and actions [118]. The “where” pathway.

Although the distinction between ventral and dorsal pathways is well-established [98], this is probably a simplification [150].

Schematic of the Visual Cortex

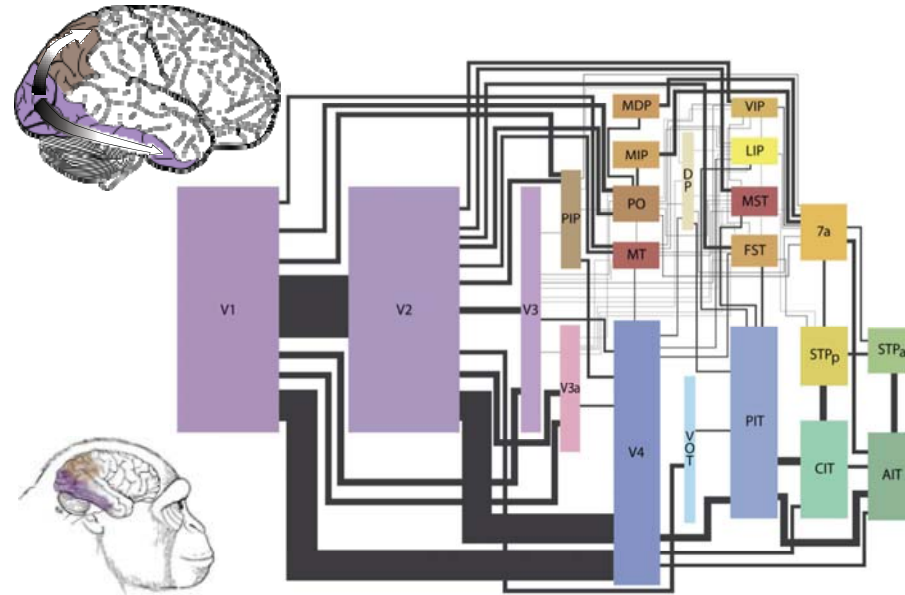

Figure 11: Left panel (top and bottom) illustrate the monkey visual cortex. The right panel is a schematic of connections between visual cortical areas in the macaque monkey brain. The colored rectangles represent visual areas (see [35]). The black lines show the connections between areas, with the thickness proportional to the number of feedforward fibers. Areas in cool and warm tones belong to the ventral and dorsal streams, respectively. (Figure adapted from [173]; see also [99]).

A schematic of the visual processing hierarchy

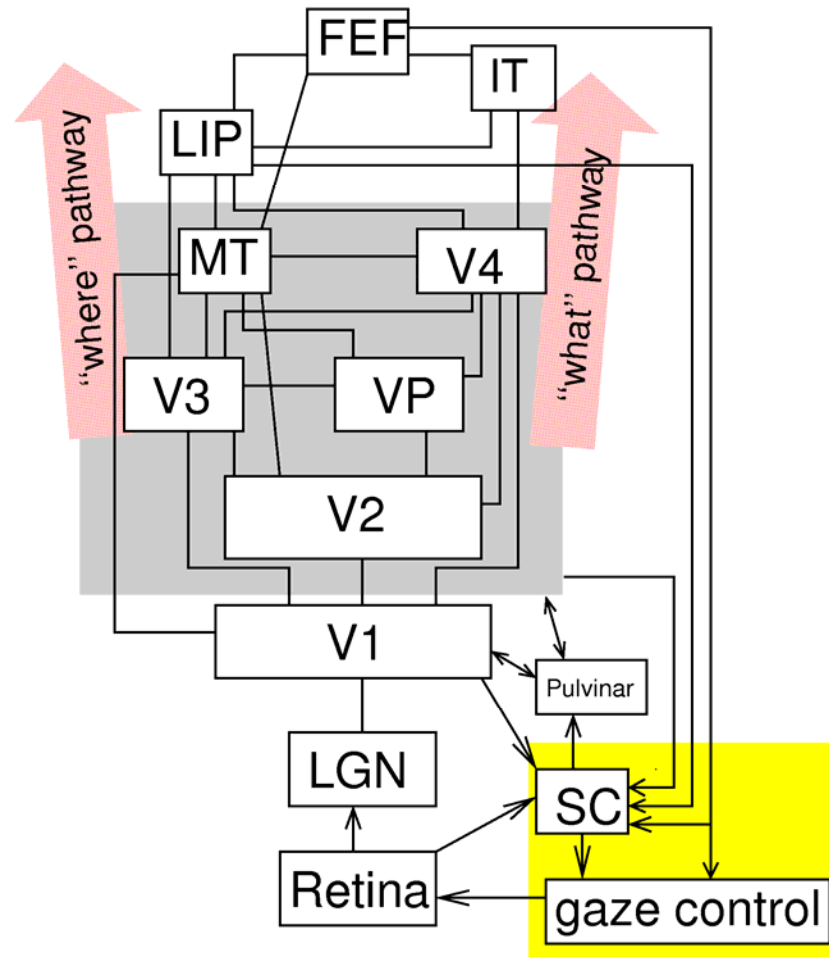

Figure from "Understanding Vision: theory, models, and data", by Li Zhaoping, Oxford University Press, 2014

Sizes of Visual Areas

The size of the visual areas varies greatly.

The first two areas, V1 and V2 are enormous and together account for roughly seventy percent of the number of neurons in the visual cortex (hence thirty percent of the neurons in the entire cortex).

The size of V1 is much bigger, by a factor of at least two hundred, than the number of fibers that leave the eye. Indeed it has been estimated that this is much more, by a factor of several hundred, than the amount needed to represent the information conveyed by the LGN [98], consistent with the idea that the purpose of V1 is to start interpreting the image instead of simply encoding it.

Another major feature of the hierarchy of visual areas is that their size get progressively smaller as one rises in the hierarchy. For example, V4 is much smaller than V2, and visual areas within IT are considerably smaller than V4.

Structural Organization: Retinotopy

Electrophysiology studies the response of neurons to synthetic stimuli with different *perceptual dimensions* such as position, orientation, color, texture, shape, sensitivity to input from both eyes, and motion. Neighboring neurons in early visual areas usually respond to similar regions of the image.

These areas are roughly *retinotopic* in the sense that their spatial organization is similar to that of the image at the retina, with a spatial transformation [\[152\]](#).

This retinotopic structure is strongest in V1 and V2 and gets weaker at high visual areas. Neurons are often classified by how they are *tuned* to specific perceptual dimensions.

But neurons in V1 respond to several dimensions [\[98\]](#) and classification is challenging in higher areas [\[144, 142\]](#). Mapping has also been done using optical techniques [\[106, 82\]](#) which also show that most early visual areas are organized retinotopically, although this is strongest in V1 and V2.

A: Retinotomic map in V1

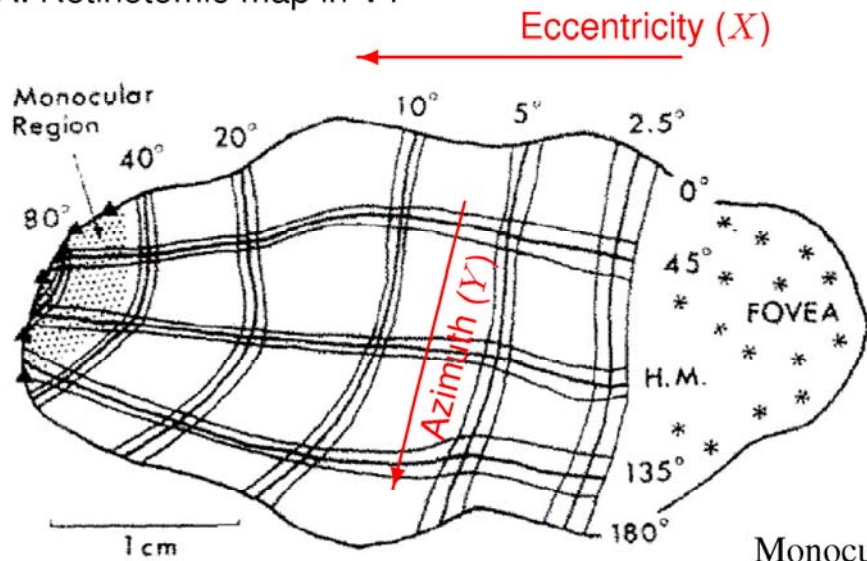

B: Half of visual space

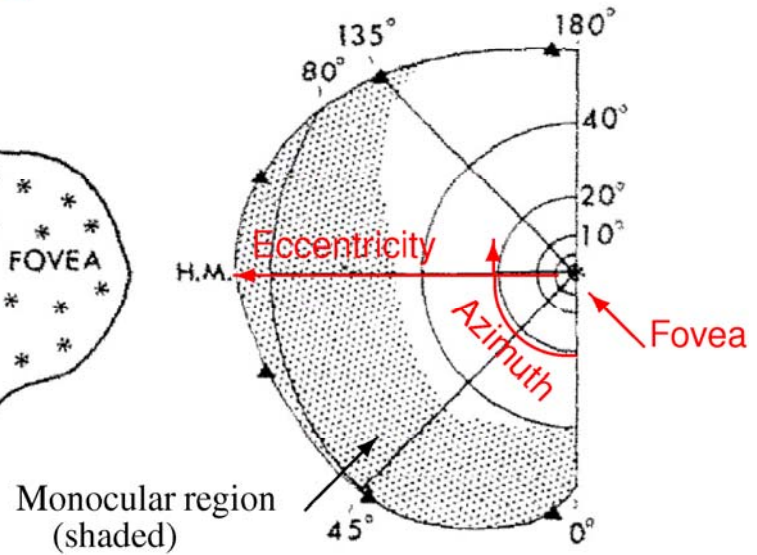

Figure from "Understanding Vision: theory, models, and data", by Li Zhaoping, Oxford University Press, 2014

Other salient structure

Other salient structures of V1 include *hypercolumns* (~1-2 mm) consisting of:

- (i) a regular array of orientation columns, perpendicular to the cortical surface, in which orientation selectivity of neurons is approximately the same and varies slowly parallel to the cortical surface;
- (ii) ocular dominance columns (where the proportion of input from both eyes is constant within each column, but varies smoothly between columns), and
- (iii) a lattice of cytochrome oxidase blobs – sensitive to color [\[65, 104\]](#).

From a more abstract perspective, the organizational structures of hypercolumns can be partly explained by the need to map stimulus dimensions (e.g. retinal position, orientation, etc.) onto two-dimensional cortical surface while attempting to make the map as smooth as possible (this is not possible, on topological grounds, so discontinuities occur) [\[30\]](#).

A: Visual objects and disparities

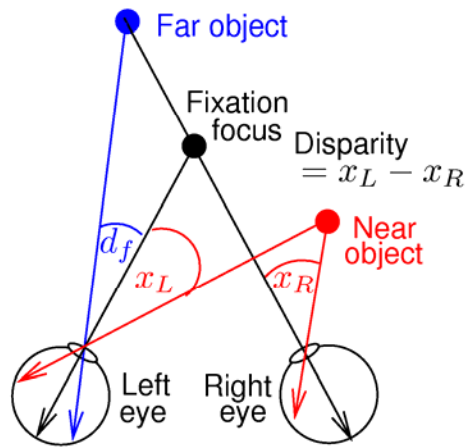

B: Two receptive fields for a single neuron

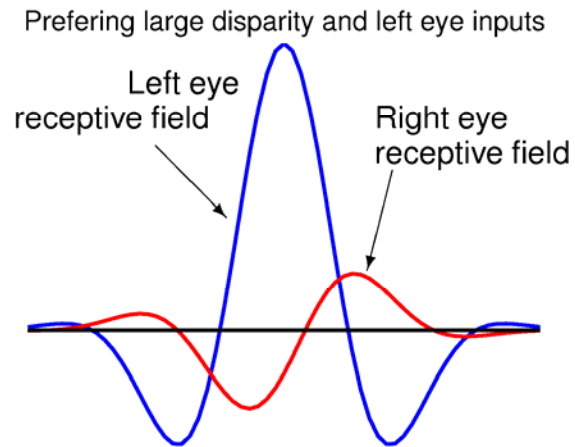

C: Ocular dominance columns imaged on the cortical surface V1 and V2

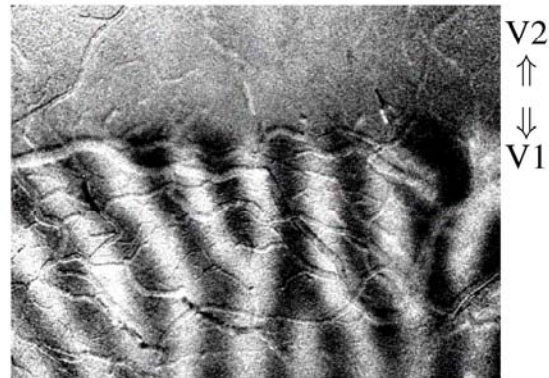

Hierarchical Organization

A notable property of these visual areas is their hierarchical organization, which relates to the distinction between low-, mid-, and high-levels.

Broadly speaking, V1 and MT seem to be involved in low-level processing, V2, V4, MST in mid-level vision, and high-level vision in IT. Hence early vision is believed to be mostly performed in V1, V2, V4, MT, and MST.

There is a strong tendency for receptive fields to be larger as we ascend the visual hierarchy. Compared to those in V1, the receptive fields are 2-3 times bigger in V2, 4-5 times larger in V3/VP, and 7-10 times larger in MT. But, conversely, the receptive fields become increasingly specific to stimuli, and stimuli of greater complexity, as we move up the ventral stream.

In summary, the receptive fields become more invariant to position and more specific to structure as we proceed up the ventral stream from V1 to V2 to IT [145][105].